



Sun FLeX Series Solenoid Valves

HIGH RELIABILITY

Designed & tested to 10-million operational cycles at full rated pressure

ADJUSTABLE RELIEF FUNCTIONS

Ideal for use in fixed-displacement pump applications

USES 740 & 747 SERIES COILS

High-power & hazardous location coils

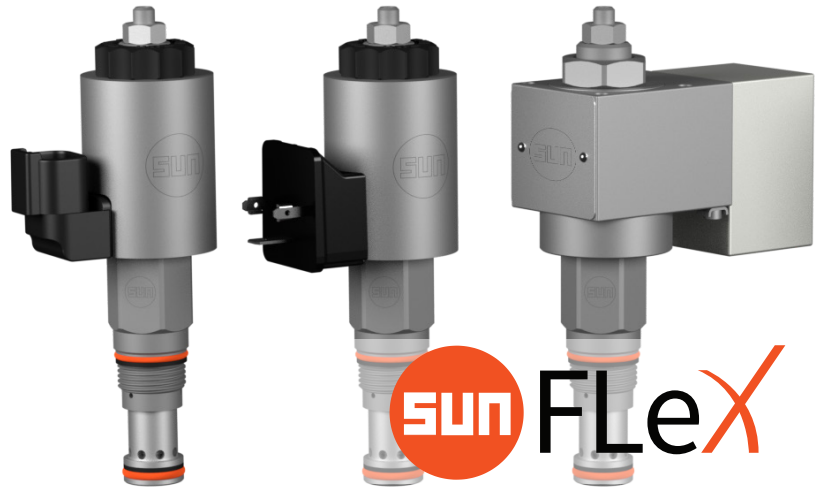

RVC*

5000 psi (350 bar)
T-10A cavity

2-STAGE, SOLENOID-OPERATED ADJUSTABLE RELIEF VALVES

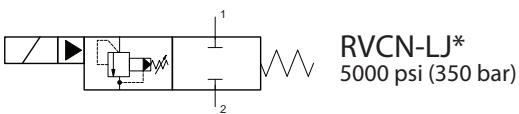
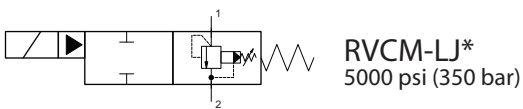
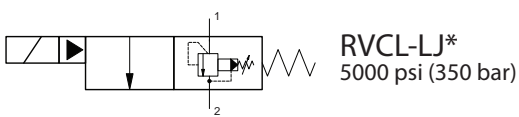
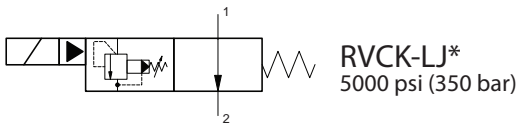

TABLE OF CONTENTS

Technical Features	2
Model Configurations & Options	3
Technical Specifications	4
Performance Curves	4
Symbols & Cavity Information	5
Applications	6
Dimensional Drawings	8

sunhydraulics.com/model/RVC*

RVC* 2-STAGE, SOLENOID-OPERATED ADJUSTABLE RELIEF VALVE

SERIES 1, CAVITY: T-10A

Solenoid-operated, 2-stage, adjustable balanced piston relief cartridges are pressure regulating valves. Energizing the solenoid activates or deactivates the relief function. Four versions are available.

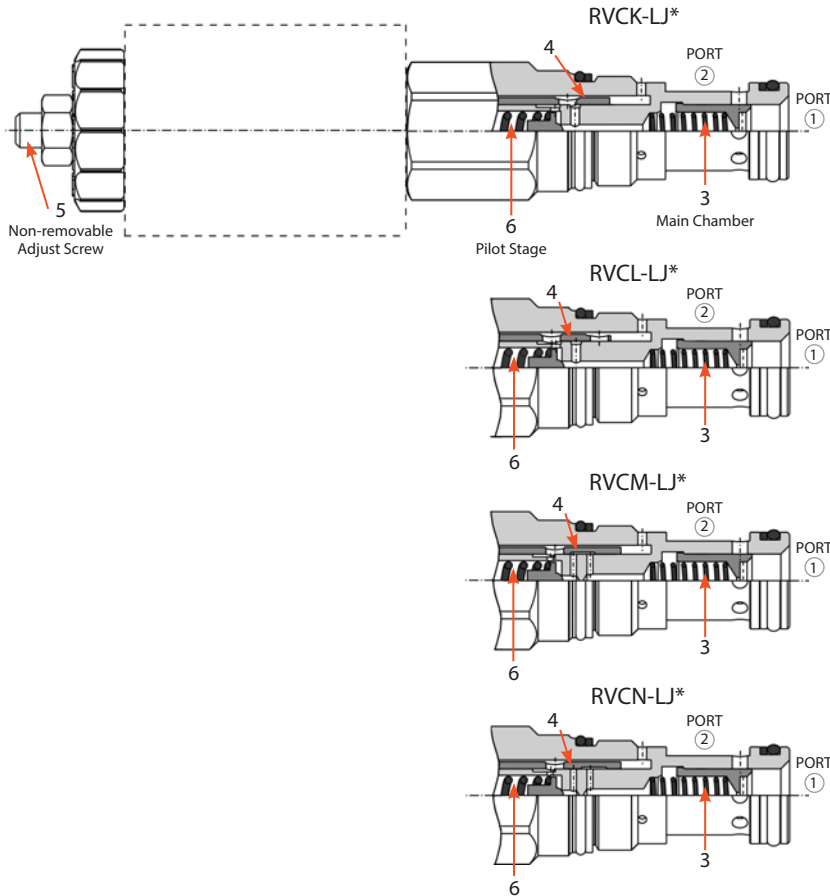

RVCK-LJ*

Function: The RVCK is normally vented. The pressure drop from port 1 (supply, pump) to port 2 (tank) is typically 100 psi (see performance curves). When the solenoid is energized, the tube (4) moves and blocks the direct connection between main chamber (3) and tank (port 2). Pilot flow can no longer flow to tank directly. The valve is in relief mode. The pressure setting is adjustable (5).

RVCL-LJ*

Function: The RVCL is normally in relief mode. The pressure setting is adjustable (5). When the solenoid is energized, the tube moves and opens a direct connection between main chamber (3) and tank (port 2). The valve is now vented. Pressure drop from port 1 (supply, pump) to port 2 (tank) is typically 100 psi (see performance curves).

RVCM-LJ*

Function: The RVCM is normally in relief mode. The pressure setting is adjustable (5). When the solenoid is energized, the tube (4) moves and blocks the connection between main chamber (3) and pilot stage (6). Without pilot flow, the main chamber is closed. The valve blocks the flow path from port 1 to port 2 like a spool-type directional valve.

RVCN-LJ*

Function: The RVCN is normally blocked. De-energized, the valve blocks the flow path from port 1 to port 2 like a spool-type directional valve. When the solenoid is energized, the tube (4) moves and allows flow through the main chamber (3) to the pilot stage (6). The valve is in relief mode. The pressure setting is adjustable (5).

TECHNICAL FEATURES

- All FLeX Series valves incorporate the Sun floating-style construction.
- Designed and tested to 10-million operational cycles at full rated pressure.
- Exceeds the new NFPA test standard T2.6.1 R2014 for fatigue and burst pressure ratings.
- A 150-micron stainless steel screen protects the main stage orifice of all valves.
- Zinc-nickel plating standard for 1000-hour salt fog protection.
- All RVC* valves are adjustable under pressure, featuring a leak-free adjustment screw with a mechanical stop to prevent the screw from backing out.
- All valves in the RVC* family use the high-power (25-W) and hazardous location coils. See table on page 3 .
- Coil connector options offer ratings up to IP69K. See individual coil product pages for details.
- Includes high flow rates of 25 gpm (100 L/min).
- FLeX Series solenoid valves are compatible with the XMD Mobile Drivers from Sun.
- U.S. Patent Numbers: RVCK 10,533,584; RVCL 10,557,483; RVCM 10, 570,932; RVCN 10,774,853

MODEL CODE EXPLANATION

Sun cartridges have a base seven-digit part number. Each of the digits in the sequence has significance as shown in the model code explanation below. Available options and

modifiers for specific cartridges, manifolds, and valve packages are shown on the individual product pages and data sheets. Not all modifiers are applicable for every model.

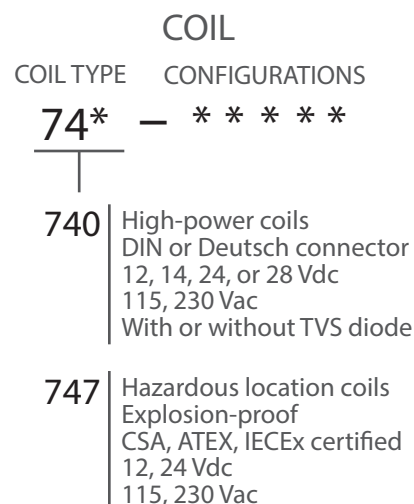
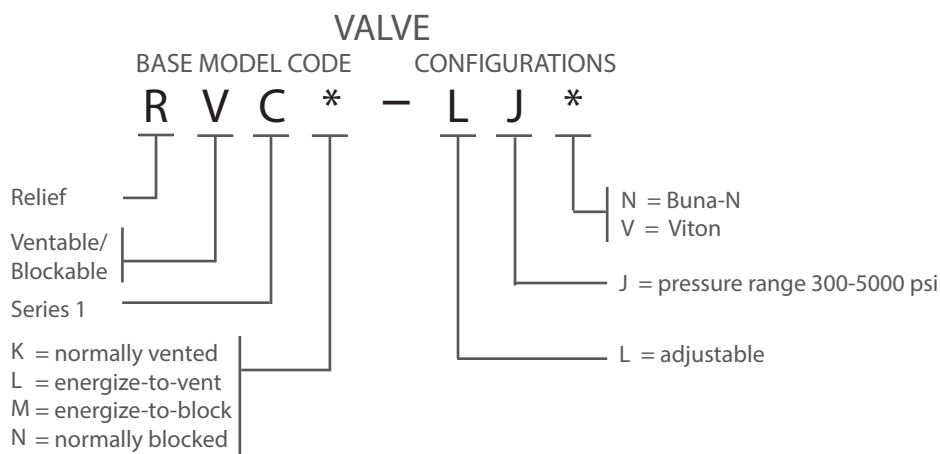

Important Note:

When performing model code searches on www.sunhydraulics.com, do not include setting(s). When ordering, no spaces or dashes are used.

See individual coil data sheets for full coil configuration.

COMPATIBLE COILS

The RVC*-LJ* valves use the 740 Series high-power (25-W) and 747 Series hazardous location coils.

High-Power (25-W) Coils

Voltage	DIN 43650 Form A (IP65/IP67)	Deutsch DT04-2P (IP69K)	Resistance @20°C (ohms) ±10% (with diode*)	TVS Diode (Nominal) Breakdown Voltage (with diode*)
	High-Power	High-Power	High-Power	
12 Vdc	740-212	740-912	5.8 Ω	68 Vdc
14 Vdc	740-214	740-914	7.8 Ω	68 Vdc
24 Vdc	740-224	740-924	23.0 Ω	68 Vdc
28 Vdc	740-228	740-928	31.4 Ω	68 Vdc
115 Vac	740-211	N/A	416 Ω	250 Vac
230 Vac	740-223	N/A	1686 Ω	400 Vac

* Above model codes are shown without transient voltage suppression (TVS) diodes. To order 740 Series coils with a TVS diode, append model code with "D" (Example: 740-212D).

Hazardous Location, Explosion-Proof (30-W) Coils

Voltage	M20 x 1.5 180°	M20 x 1.5 90°	1/2" NPT 180°	1/2" NPT 90°	Wattage @ 20°C	Circuitry
12 Vdc	747-JM12BD	747-JM12CD	747-JN12BD	747-JN12CD	29.6 W	With diode
24 Vdc	747-JM24BD	747-JM24CD	747-JN24BD	747-JN24CD	29.9 W	With diode
115 Vac	747-JM11BD	747-JM11CD	747-JN11BD	747-JN11CD	29.7 W	Rectified
230 Vac	747-JM23BD	747-JM23CD	747-JN23BD	747-JN23CD	28.9 W	Rectified

TECHNICAL SPECIFICATIONS

FLeX Series

RVC* 2-STAGE, SOLENOID-OPERATED
ADJUSTABLE RELIEF VALVE

SERIES 1, CAVITY: T-10A

TECHNICAL SPECIFICATIONS	RVCK	RVCL	RVCM	RVCN
Maximum Internal Leakage at 110 SUS (24 cSt)	5.0 in ³ /min (80 cc/min) at 2000 psi (140 bar)		5.0 in ³ /min (80 cc/min) at 3000 psi (210 bar) when blocked	
Nominal Flow Rate/Capacity	25 gpm (100 L/min)			
Maximum Operating Pressure	5000 psi (350 bar)			
Sun Cavity	T-10A			
Sun Cartridge Series	Series 1			
Factory Pressure Setting Established	4 gpm (15 L/min)			
Response Time - Typical Relief	10 ms			
Response Time - Typical Solenoid	50 ms			
Adjustment - No. of CW turns from Min. to Max. setting	3.5			
Valve Hex Size	7/8 in (22,2 mm)			
Valve Installation Torque	30 - 35 lbf ft (41 - 47 N-m)			
Adjustment Screw Internal Hex Size	1/8 in (3,2 mm)			
Locknut Hex Size	7/16 in (11,1 mm)			
Locknut Torque	45 - 55 lbf in (5 - 6 N-m)			
Valve Weight (excluding coil)	6.4 oz (181 g)			
Seal Kit - Buna N	990-010-007			
Seal Kit - Viton	990-010-006			

PERFORMANCE CURVES

RVC* - TYPICAL PRESSURE DIFFERENTIAL VS. FLOW

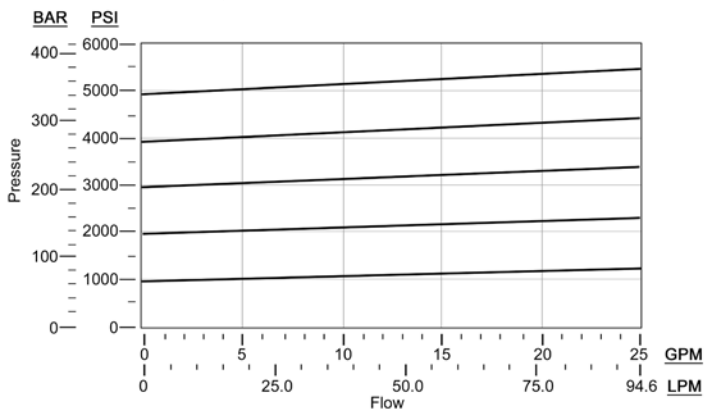

RVCK & RVCL - VENTED PRESSURE DIFFERENTIAL

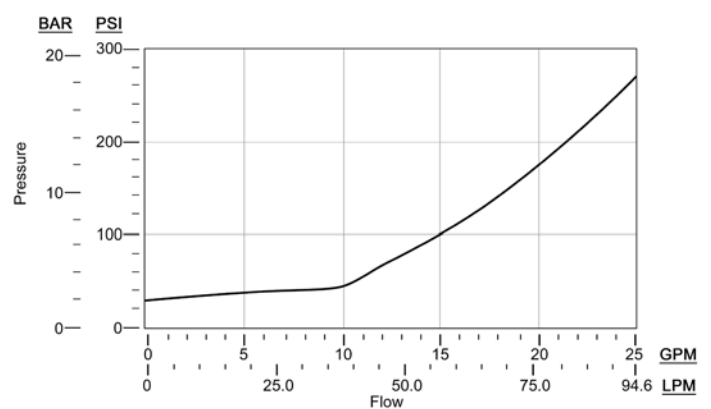

DETAILED SYMBOLS

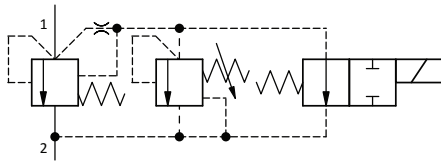

RVCK-LJ*
5000 psi (350 bar)

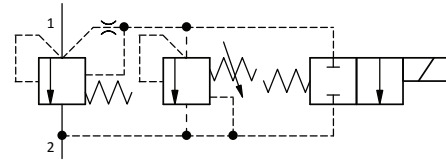

RVCL-LJ*
5000 psi (350 bar)

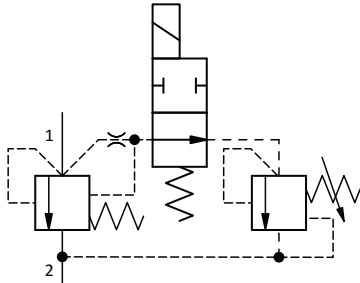

RVCM-LJ*
5000 psi (350 bar)

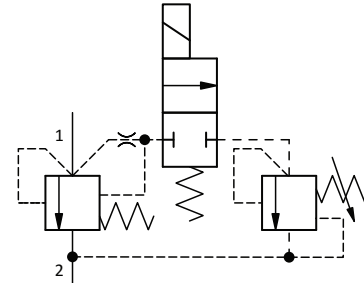

RVCN-LJ*
5000 psi (350 bar)

NOTE: Back pressure on the tank port (2) is additive to the valve setting at a 1:1 ratio.

T-10A CAVITY DIMENSIONAL DRAWING & TOOLING

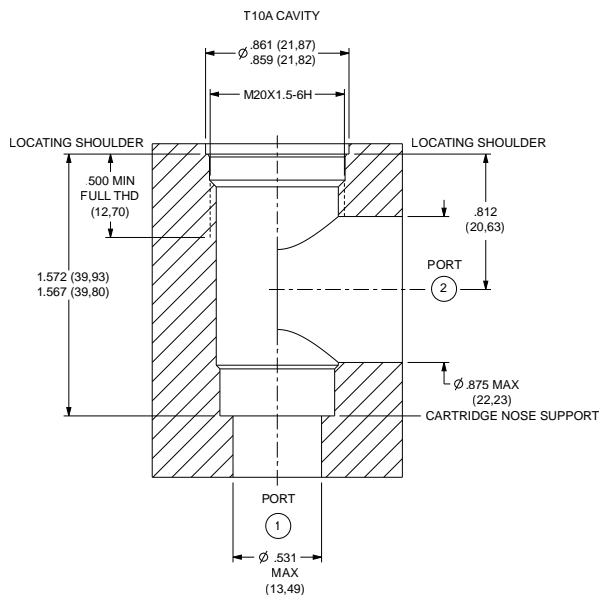

NOTE: For cavity tooling, see table below.

For full cavity detail, download the latest drawings from our website.

<https://www.sunhydraulics.com/cavity/T-10A>

DESCRIPTION	HIGH-SPEED STEEL	TITANIUM COATED
M20 X 1.5-6H tap, straight shank	998998	998998101
Series 1 deep hex socket	998100001	
T-10A cavity form drill, morse taper	994010001	994010101
T-10A cavity form drill, straight shank	994010002	994010102
T-10A cavity form reamer, morse taper	995010001	995010101
T-10A cavity form reamer, straight shank	995010002	995110102

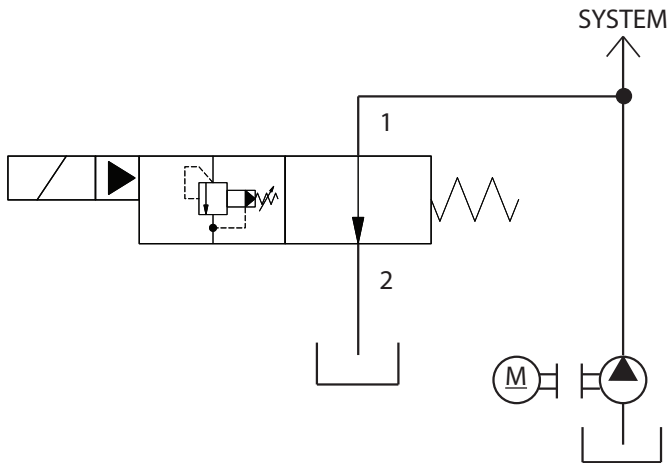

RVCK-LJ*
PUMP START-UP CIRCUIT

The normally open ventable relief RVCK is the ideal valve to use in a system when starting up a prime mover connected to a large pump with load. Unloading the pump is good practice and will be less stressful on the system. Since these valves can be switched at pressure, once the prime mover is up to full speed, the relief valve can be energized to build up system pressure. The pressure is user adjustable up to 5000 psi.

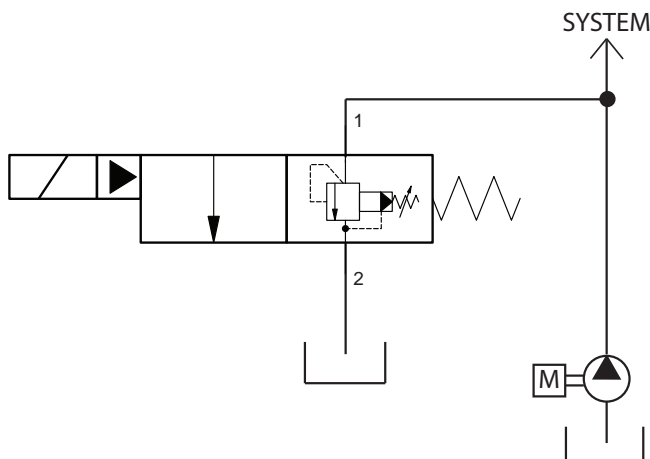

RVCL-LJ*
PUMP START-UP FOR ON/OFF FAN DRIVE CONTROL

The ventable relief RVCL is normally in relief mode. It is another option for pump start-up. Unlike the normally open RVCK, the RVCL is in relief mode when de-energized for more energy savings during normal system operation.

Because the RVCL is in relief mode when de-energized, it is only necessary to power the solenoid when the valve needs to unload during prime mover start up.

This makes the valve an obvious choice for a simple hydraulic on-off fan drive circuit as shown here and is a better choice when safety requires system pressure in the event of electric power loss.

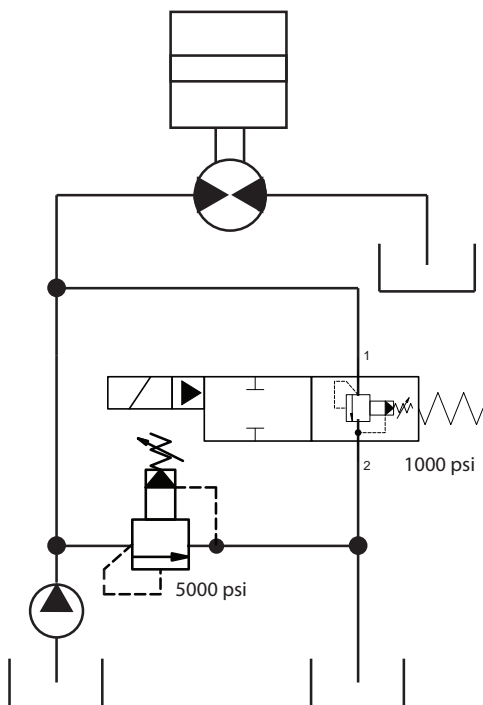

RVCM-LJ*
CONVEYOR BELT MOTOR CONTROL

The blockable relief RVCM is normally in relief mode. When energized the valve blocks flow like a spool type 2-position, 2-way valve. The valve is ideal for circuits that require two pressure setting.

In the example of a conveyor belt, the high inertia load requires a high pressure to accelerate from stop. When the conveyor is in motion and motor speed is constant, a lower relief setting maintains motion at a lower pressure.

Compared to a circuit with two relief valves and one solenoid-operated directional valve, the blockable RVCM eliminates the need for the directional valve, creating a much simpler two-valve solution instead of three.

NOTE: Sample circuits are shown for application illustration only and are not intended as circuit designs.

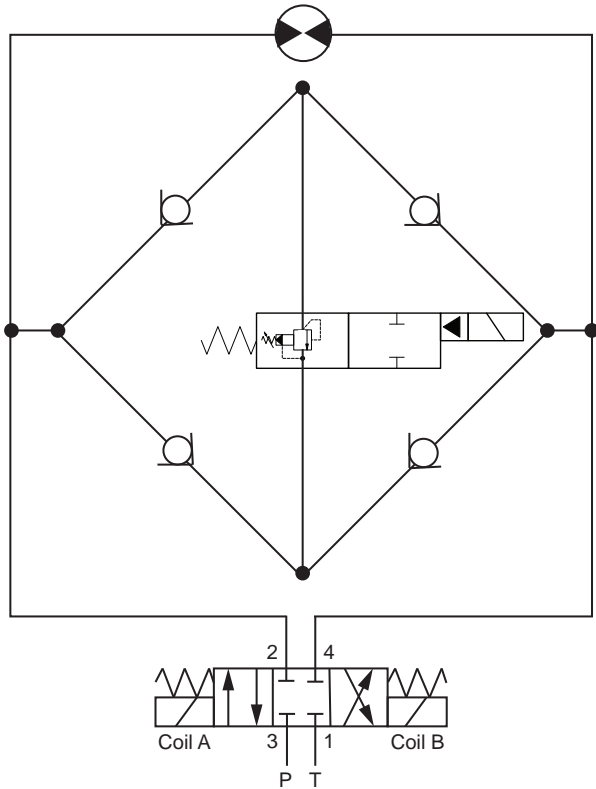

RVCM-LJ*

BI-DIRECTIONAL PUMP PRESSURE DIFFERENTIAL LIMIT

The blockable relief RVCM is normally in relief mode. The valve can be used to limit the pressure differential across the motor. The relief valve setting then allows the motor to accelerate with a limited torque using the controlled pressure, smoothing out the load movement.

In a rectifier circuit, the RVCM limits the torque of the motor in both directions.

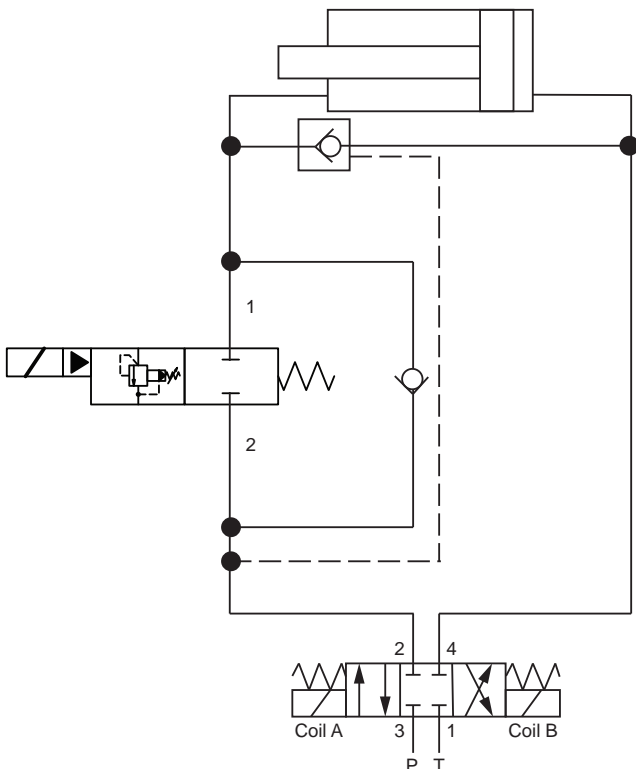

RVCN-LJ*

ADJUSTABLE COMPRESSION FOR MATERIAL COMPACTORS & BAILING PRESSES

The RVCN is normally blocked and, when energized, turns into an adjustable relief valve.

The valve can be used as a pilot-operated 2-position, 2-way valve with high capacity. When energized, the relief function of the valve can be used to avoid decompression shock. In a continuous regeneration circuit, the valve can unload the rod end side of the cylinder. Preloading the cylinder avoids the decompression shock. And because the valve is adjustable, it can be adjusted to control the amount of compression in the compactor or press when the cylinder goes from regen to normal mode.

NOTE: Sample circuits are shown for application illustration only and are not intended as circuit designs.

DIMENSIONAL DRAWINGS

RVC* FAMILY WITH 740 SERIES HIGH-POWER COILS

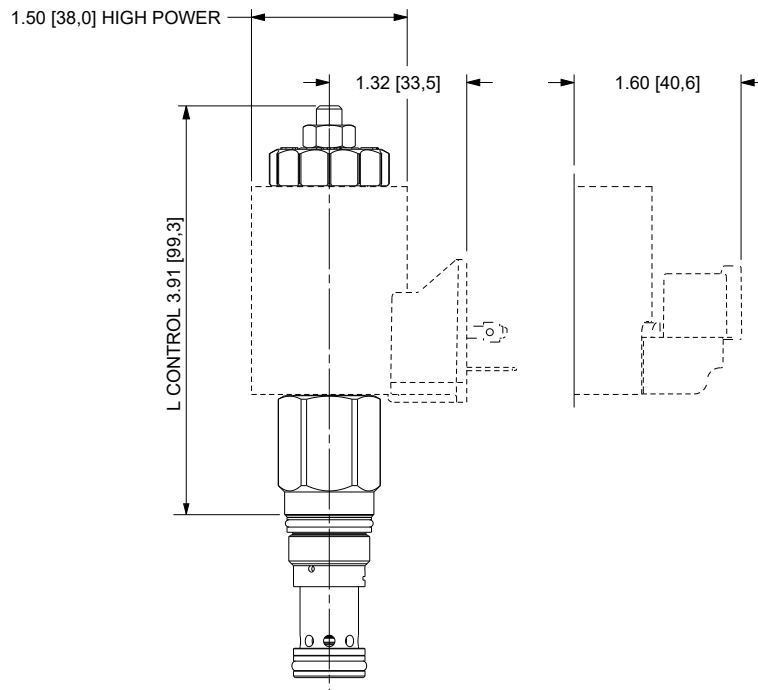

747 SERIES HAZARDOUS LOCATION COILS

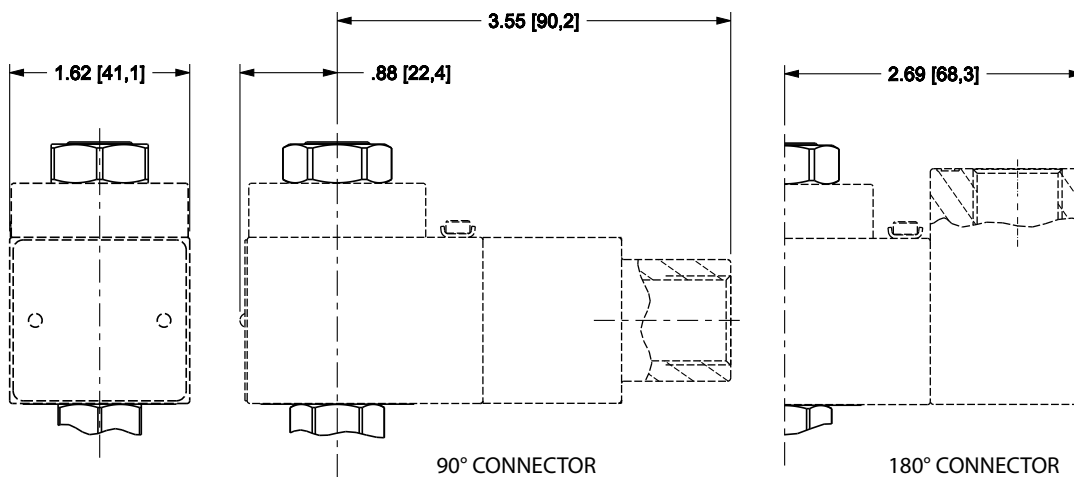

NOTE: Please verify cartridge clearance requirements when choosing a Sun manifold. Different valve controls and coils require different clearances. An additional minimum 2.0 in. (50,8 mm) beyond the valve extension is needed for coil installation and removal.



Sun Hydraulics Headquarters
Sarasota, Florida USA
+1 941 362 1200

Custom Fluidpower Pty Ltd
(A Sun Hydraulics Company)
Newcastle, Australia
+61 02 4953 5777
sales@custom.com.au

Sun Hydraulics Limited
Coventry England
+44 2476 217 400
salesuk@sunhydraulics.com

Sun Hydraulics Korea Corp.
Incheon Korea
+82 3281 31350
sales@sunhydraulics.co.kr

Sun Hydraulik GmbH
Erkelenz Germany
+49 2431 80910
salesde@sunhydraulics.com

Sun Hydraulics China Co. Ltd.
Shanghai P.R. China
+86 2162 375885
sunchinainfo@sunhydraulics.com

Sun Hydraulics Corp. (India)
Bangalore India
+91 8028 456325
sunindiainfo@sunhydraulics.com

Sun Hydraulics Corp. (S.America)
Rosario, Argentina
+54 9 341 584 3075
ventas@sunhydraulics.com

September 2021