



Sun FLeX Series Solenoid Valves

HIGH RELIABILITY

Designed & tested to exceed 10-million operational cycles at full rated pressure

LOW INTERNAL LEAKAGE

Less than one drop per minute

USES 740 & 747 SERIES DC COILS

Low-power, high-power & hazardous location coils

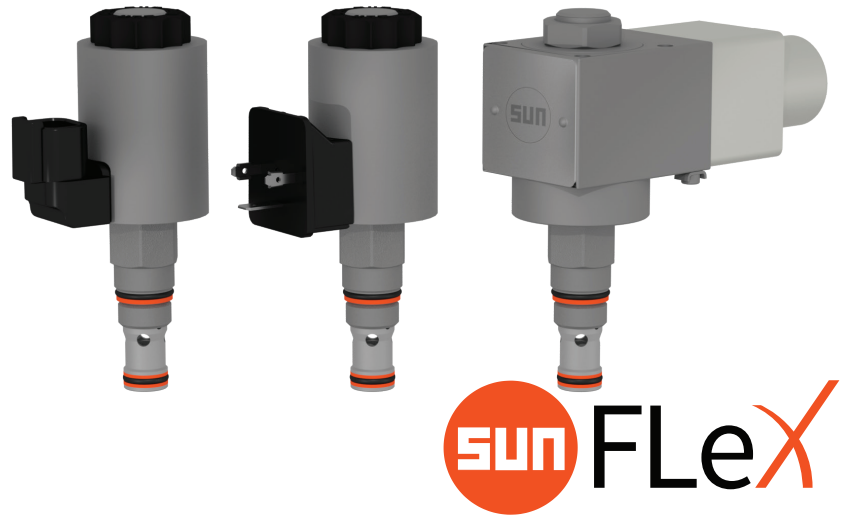

FPB*

3000 & 5000 psi
(210 & 350 bar)
T-162A cavity

PILOT-OPERATED ELECTRO-PROPORTIONAL THROTTLE VALVES

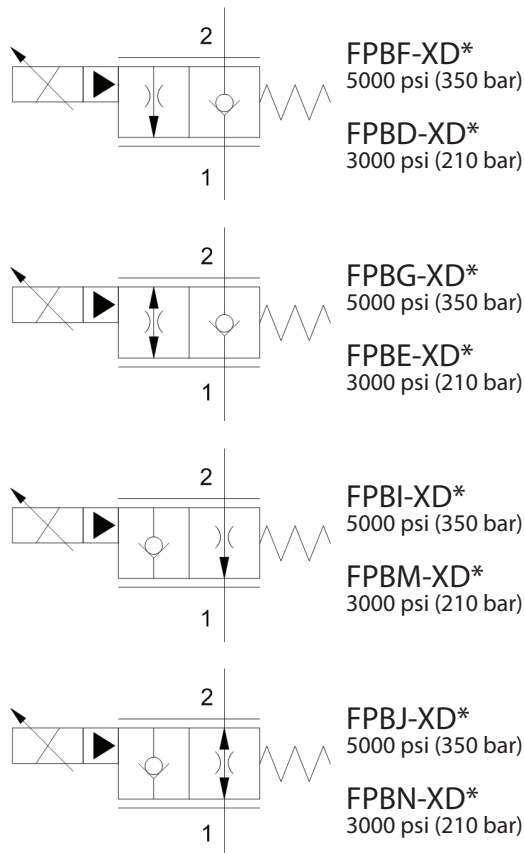

TABLE OF CONTENTS

Valve Functionality	2
Technical Features	2
Model Configurations & Options	3
Technical Specifications	4
Performance Curves	5
Dimensional Drawings	7
Cavity Drawings/Tooling	8
Accessories	8

sunhydraulics.com/model/FPB*

TECHNICAL FEATURES

FLeX Series

FPB* PILOT-OPERATED ELECTRO-PROPORTIONAL THROTTLE VALVE

The 2/2 proportional poppet valves are pilot operated. They comprise a hex body (3), solenoid with coil (2), poppet (5), dart (4), coil nut (1), ball (6), pin (7), and two springs (8) for the FPBG and FPBF, and one spring (8) for the FPBJ and FPBI.

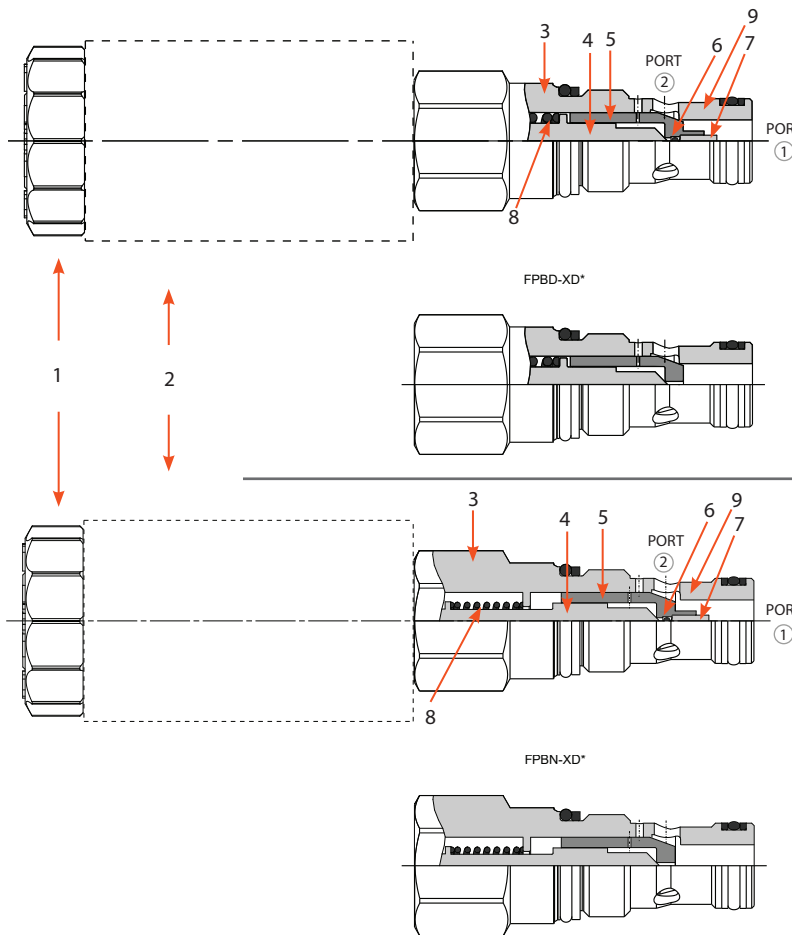

NORMALLY CLOSED

FPBG, FPBF, FPBD, and FPBE

Function: When de-energized, the dart (4) rests on the poppet (5) which in turn rests on the sleeve seat (9). In this condition, flow is blocked from 2 to 1 but will free flow from 1 to 2. When energized, the dart lifts from the poppet proportional to the coil current. The poppet then follows the dart and lifts from the seat, opening flow from 2 to 1.

If the FPBF or FPBD is open and flow is routed 1 to 2, the valve may auto close and only pilot flow will pass from 1 to 2. For the FPBG or FPBE, the check valve (6 & 7) at the nose of the poppet will allow free flow 1 to 2 whether the valve is open or closed.

NORMALLY OPEN

FPBJ, FPBI, FPBM and FPBN

Function: When de-energized, the dart (4) and poppet (5) are held away from the sleeve seat (9) by the spring (8), opening flow from 2 to 1. When energized, the dart pushes into the poppet seat proportional to the coil current. As the dart pushes against the spring, the poppet pushes into the sleeve seat, closing the valve. Flow is then blocked from 2 to 1 but can free flow from 1 to 2.

If the FPBI or FPBM is open and flow is routed from 1 to 2, the valve may auto close and only pilot flow will pass from 1 to 2. For the FPBJ or FPBN, the check valve (6 & 7) at the nose of the poppet will allow free flow 1 to 2 whether the valve is open or closed.

TECHNICAL FEATURES

- All FLeX Series valves incorporate the Sun floating-style construction to minimize the possibility of internal parts binding due to excessive installation torque and/or cavity/cartridge machining variations.
- FLeX Series proportional valves are fully compatible with the XMD Expandable Mobile Drivers from Sun.
- Designed and tested to 10-million operational cycles at full rated pressure.
- Exceeds the new NFPA test standard T2.6.1 R2014 for fatigue and burst pressure ratings.
- Improved linearity and resolution over similar competing valves.
- Designed using CFD fluid simulation for optimized geometries.
- For optimum performance, an amplifier with current feedback and adjustable dither (80 - 250 Hz) should be used. Capacities rated at 200-psi (14-bar) differential and maximum rated coil current.
- Depending on circuit requirements, a reverse free flow check bypassing the compensator may be needed when using an FPB* with an external compensator.
- Zinc-nickel plating standard for 1000-hour salt fog protection.
- The 5000 psi (350 bar) valves can be used with 740 Series high-power and 747 Series hazardous location coils.
- The 3000 psi (210 bar) valves can be used with 740 Series low-power and 747 Series hazardous location coils.
- A wide variety of coil termination and voltage options are available, with and without surge protection. See the CONFIGURATION section.
- Coil connector options offer ratings up to IP69K. See individual coil product pages for details.

MODEL CODE EXPLANATION

Sun cartridges have a base seven-digit part number. Each of the digits in the sequence has significance as shown in the model code explanation below. Available options and

modifiers for specific cartridges, manifolds, and valve packages are shown on the individual product pages and data sheets. Not all modifiers are applicable for every model.

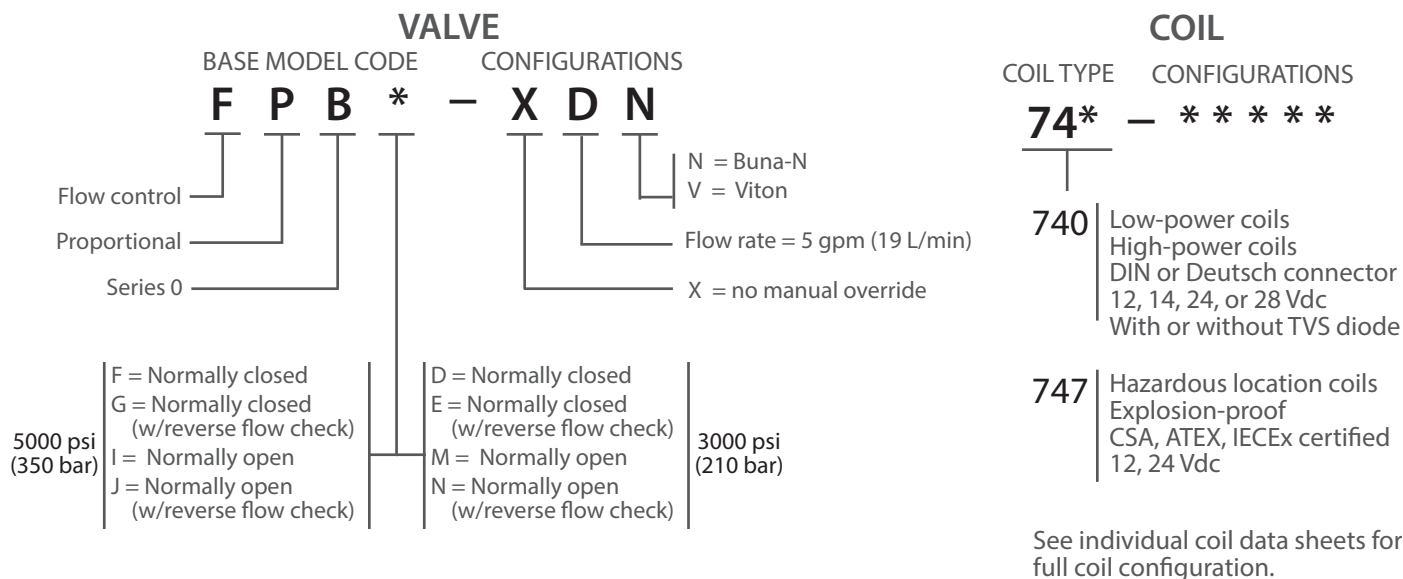

Important Note:

When performing model code searches on www.sunhydraulics.com, do not include setting(s). When ordering, no spaces or dashes are used.

COMPATIBLE FLeX SERIES COILS

Low-Power (17-W)* & High-Power (25-W) Coils

Voltage	DIN 43650 Form A (IP65/IP67)		Deutsch DT04-2P (IP69K)		Resistance @20°C (ohms) ±10% (with diode*)		TVS Diode (Nominal) Breakdown Voltage (with diode*)
	High-Power	Low-Power	High-Power	Low-Power	High-Power	Low-Power	
12 Vdc	740-212	740-212L	740-912	740-912L	5.8 Ω	8.5 Ω	68 Vdc
14 Vdc	740-214	740-214L	740-914	740-914L	7.8 Ω	11.5 Ω	68 Vdc
24 Vdc	740-224	740-224L	740-924	740-924L	23.0 Ω	33.9 Ω	68 Vdc
28 Vdc	740-228	740-228L	740-928	740-928L	31.4 Ω	46.1 Ω	68 Vdc

* The low-power coils are for use with the 3000 psi (210 bar) valves only.

** Above model codes are shown without transient voltage suppression (TVS) diodes. To order 740 Series coils with a TVS diode, append model code with "D" (Example: 740-212LD).

Hazardous Location, Explosion-Proof (30-W) Coils

Voltage	M20 x 1.5 180°	M20 x 1.5 90°	1/2" NPT 180°	1/2" NPT 90°	Wattage @ 20°C	Circuitry
12 Vdc	747-JM12BD	747-JM12CD	747-JN12BD	747-JN12CD	29.6 W	With diode
24 Vdc	747-JM24BD	747-JM24CD	747-JN24BD	747-JN24CD	29.9 W	With diode

TECHNICAL SPECIFICATIONS

FLeX Series



PILOT-OPERATED ELECTRO-
PROPORTIONAL THROTTLE VALVE

SERIES 0, CAVITY: T-162A

TECHNICAL SPECIFICATIONS	FPBF, FPBG, FPBI, FPBJ	FPBD, FPBE, FPBM, FPBN
Maximum Operating Pressure	5000 psi (350 bar)	3000 psi (210 bar)
Sun Cavity	T-162A	
Sun Cartridge Series	Series 0	
Nominal Flow Rate/Capacity	5 gpm (18.9 L/min)*	
Check Cracking Pressure - Typical	100 psi (6.9 bar)	
Response Time - Typical	50 ms (open & close)	
Maximum Internal Leakage at 110 SUS (24 cSt) at 5000 psi (350 bar)	0.004 in ³ (0.07 cm ³)/min (1 drop/min)	
Switching Frequency (Maximum)	4.17 Hz (15,000 cycles/hour)	
Recommended Dither Frequency	140 Hz**	
Hysteresis (at Recommended Dither)	15%	
Linearity (at Recommended Dither)	3%	
Repeatability (at Recommended Dither)	3%	
Deadband, Nominal (as Percent of Coil Current)	48%	
Manual Override Option	No	
Viscosity Range	2,8 to 380 cSt or 35 to 2000 SUS	
Filtration	Minimum cleanliness (ISO 4406 1999, 4/6/14 µm) 18/16/13	
Valve Hex Size	0.75 in (19,1 mm)	
Valve Installation Torque	20-25 lbf ft (27-34 N-m)	
Mounting Position	No restrictions	
Valve Weight (excluding coil)	5.6 oz (159 g)	
Seal Kit - Viton	990-608-006	
Seal Kit - Buna	990-608-007	

* See performance curves for more details.

** We recommend a 140-Hz dither frequency be used as a starting point when tuning the amplifier and valve in a system.

TYPICAL FLOW VS. COMMAND - 5000 psi (350 bar) Valves

FPBF
(Normally closed)

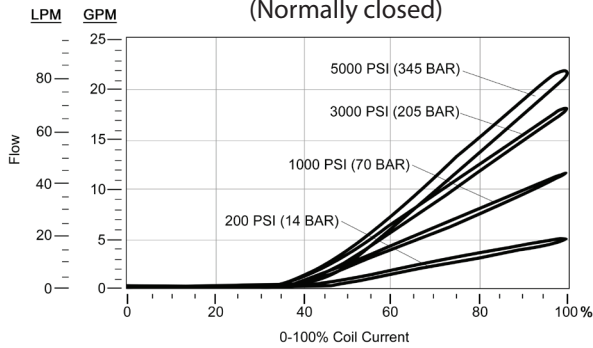

FPBG
(Normally closed)

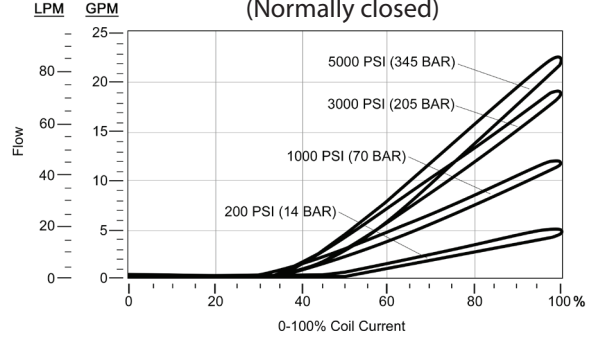

FPBI
(Normally open)

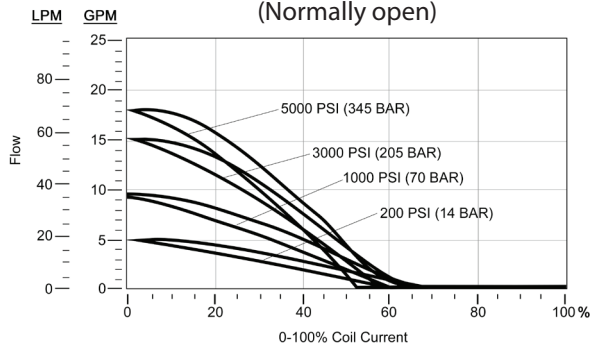

FPBJ
(Normally open)

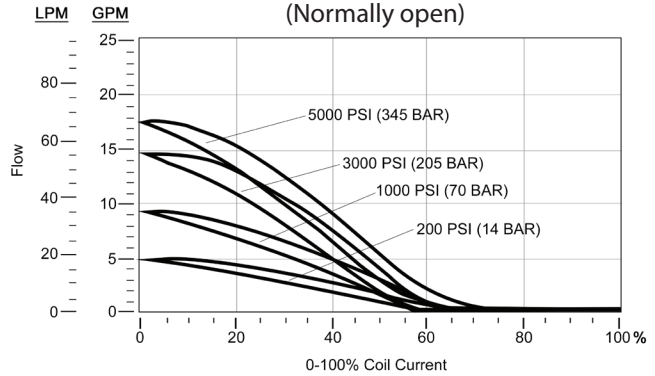

TYPICAL PRESSURE DIFFERENTIAL VS. FLOW - 5000 psi (350 bar) Valves

FPBF
(Normally closed)

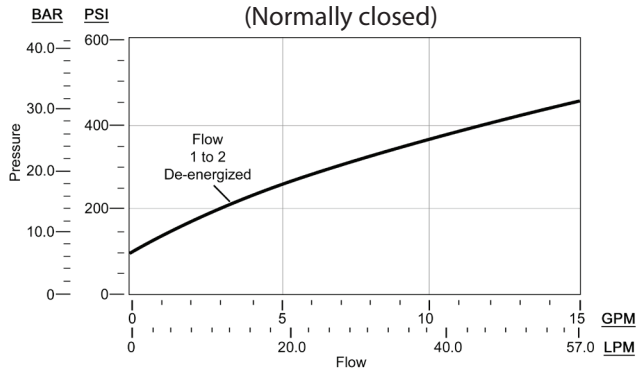

FPBG
(Normally closed)

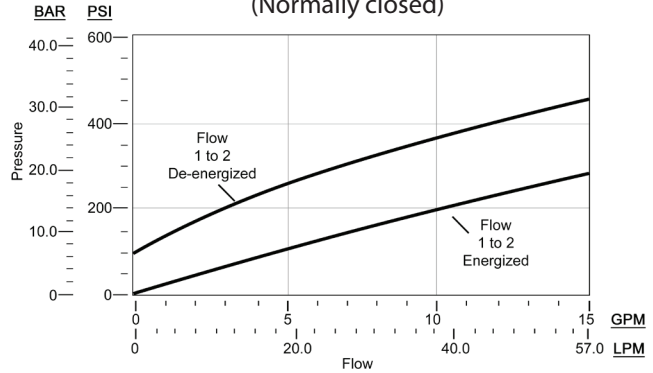

FPBI
(Normally open)

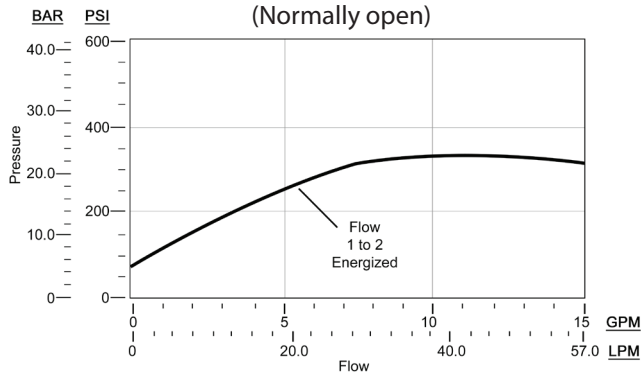

FPBJ
(Normally open)

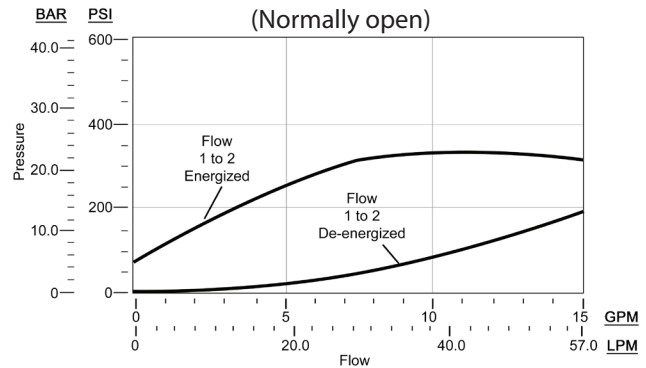

TYPICAL FLOW VS. COMMAND - 3000 psi (210 bar) Valves

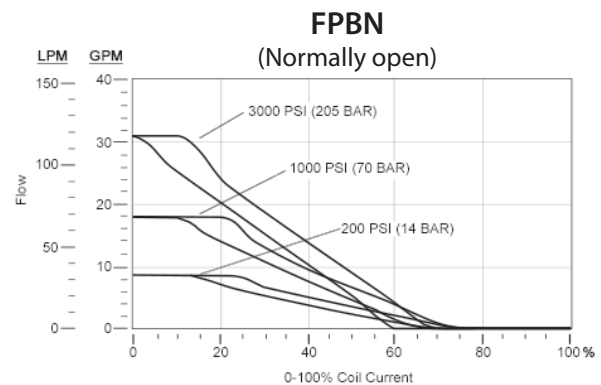
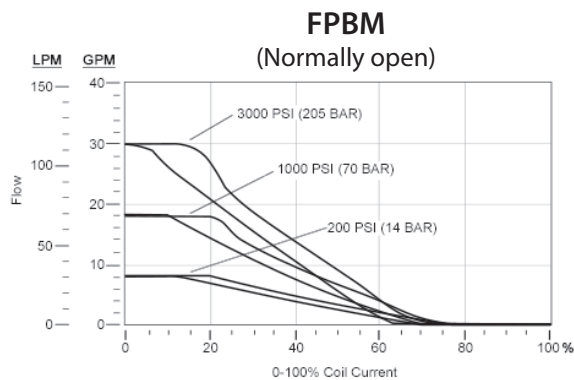
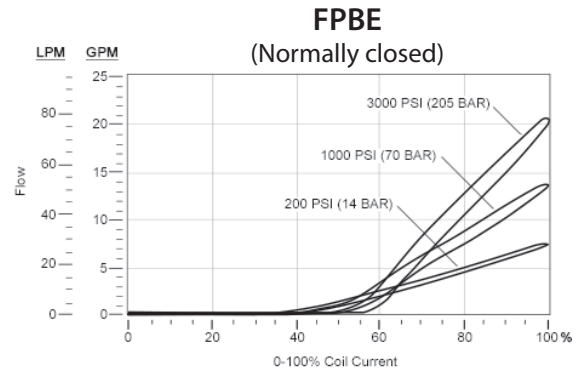
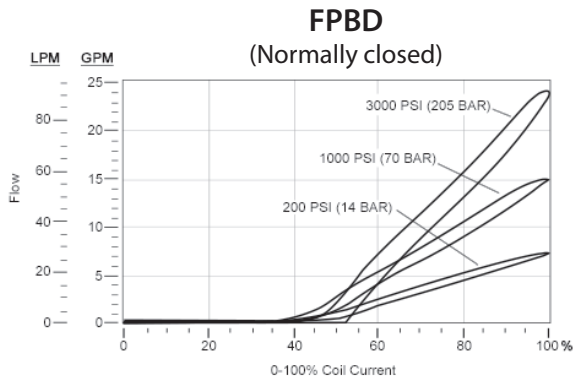

TYPICAL PRESSURE DIFFERENTIAL VS. FLOW - 3000 psi (210 bar) Valves

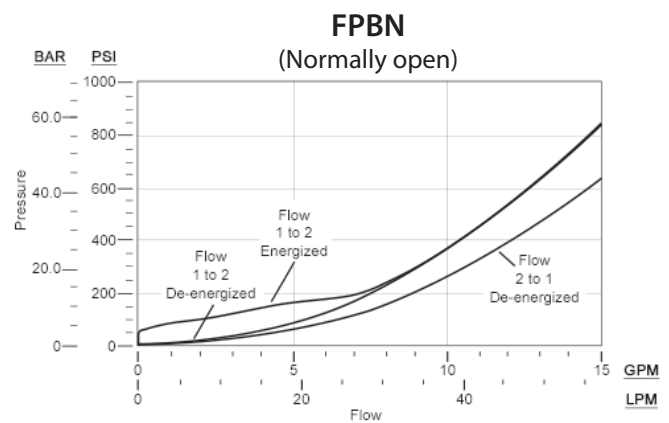
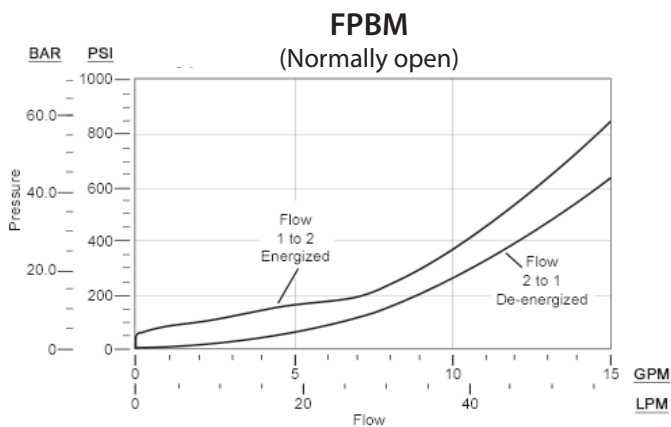
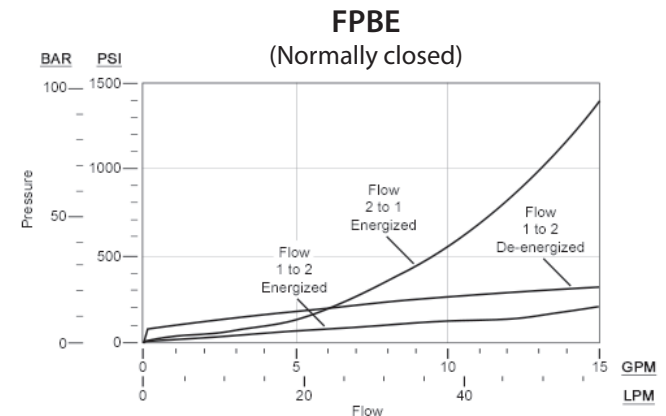
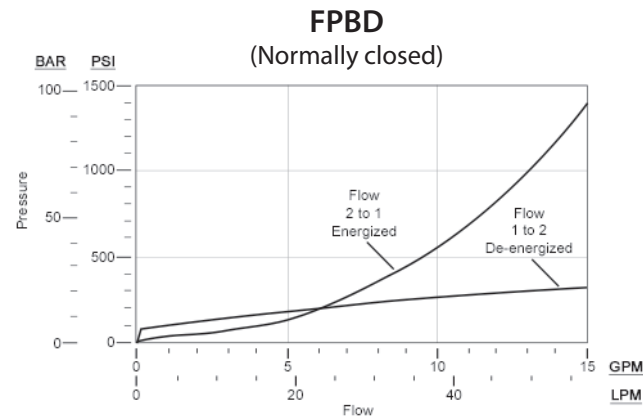

FPB* FAMILY WITH 740 SERIES LOW- & HIGH-POWER COILS

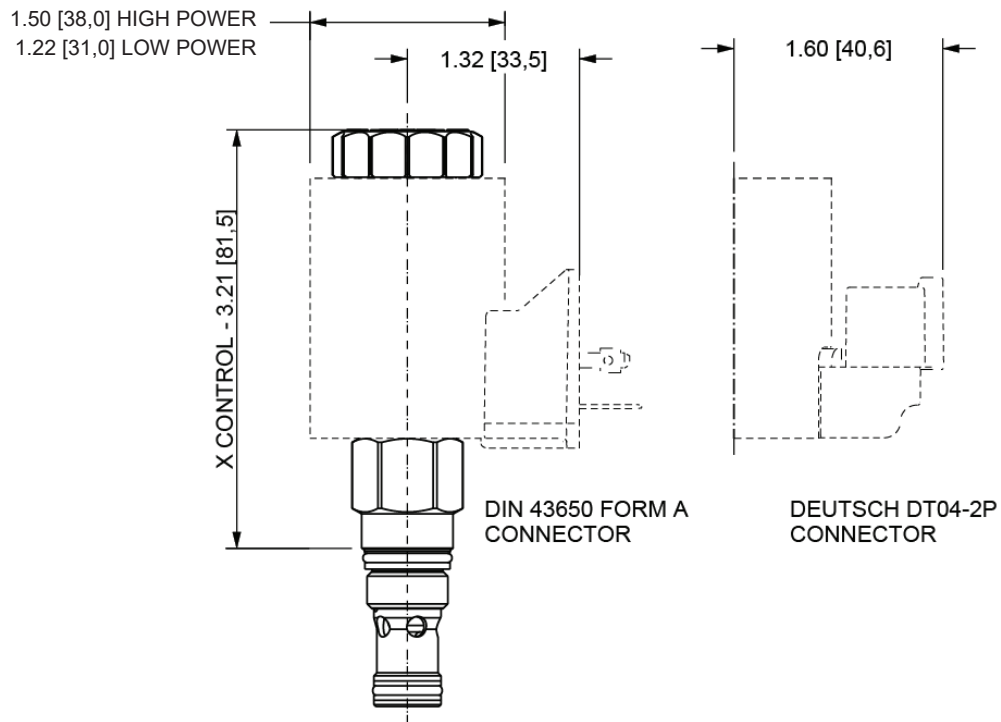

747 SERIES HAZARDOUS LOCATION COILS

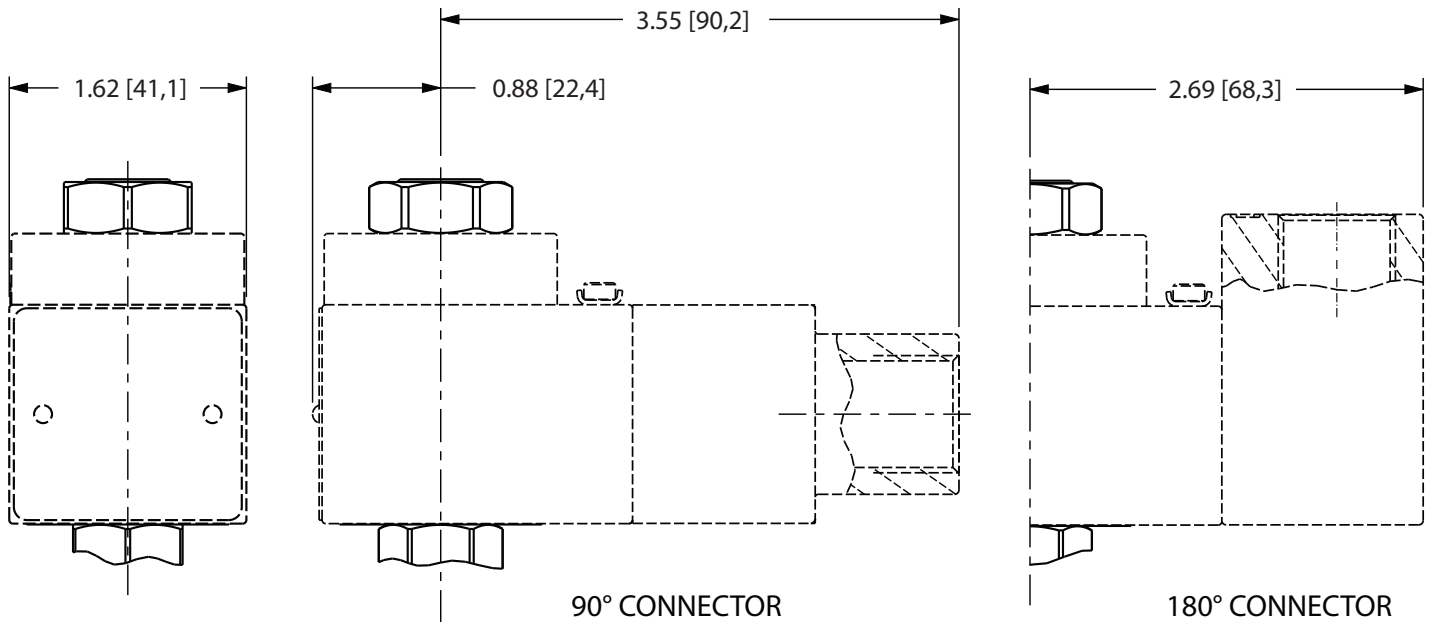

NOTE: Please verify cartridge clearance requirements when choosing a Sun manifold. Different valve controls and coils require different clearances. An additional minimum 2.0 in. (50,8 mm) beyond the valve extension is needed for coil installation and removal.

T-162A CAVITY DIMENSIONAL DRAWING

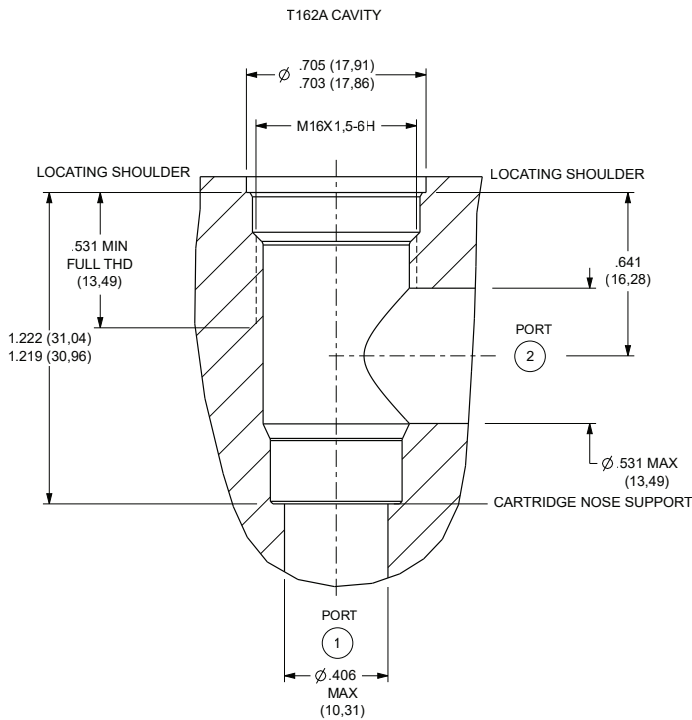

NOTE: For cavity tooling, see table below.

For full cavity detail, download the latest drawings from our website.

www.sunhydraulics.com/cavity/T-162A

DESCRIPTION	HIGH-SPEED STEEL	TITANIUM COATED
M16 X 1.5-6H tap, straight shank	998991	998991101
Series 0 deep hex socket	998100005	
T-162A cavity form drill, morse taper	994162001	994162101
T-162A cavity form drill, straight shank		994162102
T-162A cavity form reamer, morse taper	995162001	995162101
T-162A cavity form reamer, straight shank		995162102

ACCESSORIES

XMD Single- and Dual-Output Drivers

The XMD is a single- or dual-output driver used with solenoid-operated electro-proportional valves for the mobile and industrial hydraulic industries. The driver can be mounted on a manifold using the standard mount clip or directly to the 740 Series low- and high-power coils using an optional coil-mount clip.

DESCRIPTION	PART NUMBER
Single-output PWM driver w/ standard mounting bracket	XMD-01
Dual-output PWM driver w/ standard mounting bracket	XMD-02



Wire Harnesses

DESCRIPTION	PART NUMBER
Wire harness, 2-pin Deutsch-to-Metri-Pack Conversion	991-717
Wire harness, 2-pin Deutsch-to-Amp Jr Timer Conversion	991-718
Wire harness, 2-pin Deutsch-to-Twin-Lead Conversion	991-719



Sun Hydraulics Headquarters
Sarasota, Florida USA
+1 941 362 1200

Custom Fluidpower Pty Ltd
(A Sun Hydraulics Company)
Newcastle, Australia
+61 02 4953 5777
sales@custom.com.au

Sun Hydraulics Limited
Coventry, England
+44 2476 217 400
sales@sunuk.com

Sun Hydraulics Korea Corp.
Incheon, Korea
+82 3281 31350
sales@sunhydraulics.co.kr

Sun Hydraulik GmbH
Erkelenz, Germany
+49 2431 80910
sales@sunhydraulik.de

Sun Hydraulics China Co. Ltd.
Shanghai, P.R. China
+86 2162 375885
sunchinainfo@sunhydraulics.com

Sun Hydraulics Corp. (India)
Bangalore, India
+91 8028 456325
sunindiainfo@sunhydraulics.com

Sun Hydraulics Corp. (S.America)
Rosario, Argentina
+54 9 341 584 3075
ventas@sunhydraulics.com

April 2019